



Commercial Vehicles

Mobile Solutions Product Overview

Breakthrough
engineering for
a better world

Contents

Introduction	02
Experience and Expertise in Commercial Vehicles	03
Our Global Reach	04
Powertrain Engine	05
Powertrain Transmission	06
Chassis/ CAB	07
Powertrain Engine Solutions	08
Solutions for Mobile Pneumatics	10
Tankers & Trailers	12
Body Builders	14
Buses & Coaches	16
Actuators	18
Fuel Systems	19
Valves	20
Air and Gas Preparation	22
Switches, Fittings, Tubings & Accessories	22

Breakthrough engineering for a better world

We're at the forefront of delivering the solutions we need in a changing world and we're focused on solving key industry problems and employing the very best people.

Our market-leading industry expertise means we offer the capability, resources, engineering intelligence and global support infrastructure to tackle even the most challenging project demands.

We're committed to helping customers achieve their goals by working with them as a partner, not just a supplier. We create unique, high-performance products based on proven automotive technology.

Our customised solutions, specific to each customer, can help to reduce emissions, provide more responsive control, reduce pressure leakage, provide greater durability and offer many other benefits, while our world-class quality maximises vehicle uptime.

With over 40 years of experience working directly with global commercial vehicle manufacturers, we offer a comprehensive range of Norgren pneumatic, hydraulic, electronic and vacuum solutions covering every major vehicle system, from the front bumper to the rear.

Breakthrough engineering you can count on.

Experience and Expertise in Commercial Vehicles

On-Highway

Our range of cab, chassis and powertrain solutions deliver fuel efficiency and emissions reduction for the world's leading commercial vehicle manufacturers. Acknowledged for their safe and reliable operation, our products are proven over millions of miles of reliable service. We understand the market trends, environmental challenges, emissions standards specifications that matter to truck manufacturers and Tier 1 suppliers.

Off-Highway

We are a specialised partner to OEM's and Tier 1 suppliers focusing on agriculture and construction segments and understand the need to develop scalable, cross-segment type solutions. Whether adopting On-High powertrain technologies or value engineering product performance according to local market requirements: Our application specialists and dedicated program teams support our customers from initial enquiry throughout program life-time.



Breakthrough
engineering for
a better world

Powertrain Engine

IMI provides high-performance pneumatic and electric control using innovative valve and actuation technology for all current and future engine control requirements.

Solutions that meet the challenging temperature and vibration requirements of today's on-highway and off-highway engines.

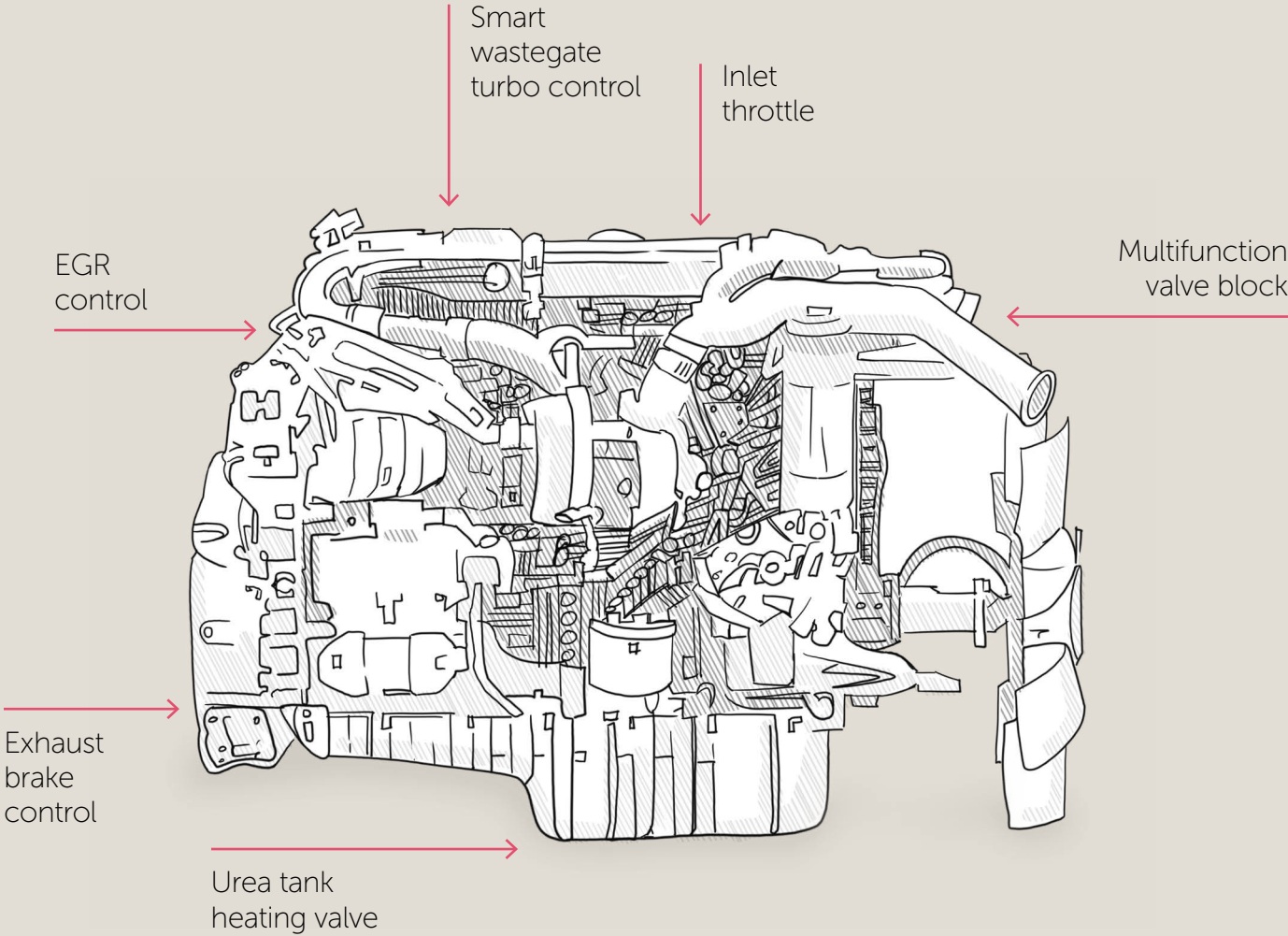

Powertrain Transmission

Modular or standard version, our Norgren transmission products are built to be reliable, robust and reduce weight.

Solutions providing pneumatic assistance on manual transmissions and high performance solenoid valve technology for automated manual transmission (AMT).

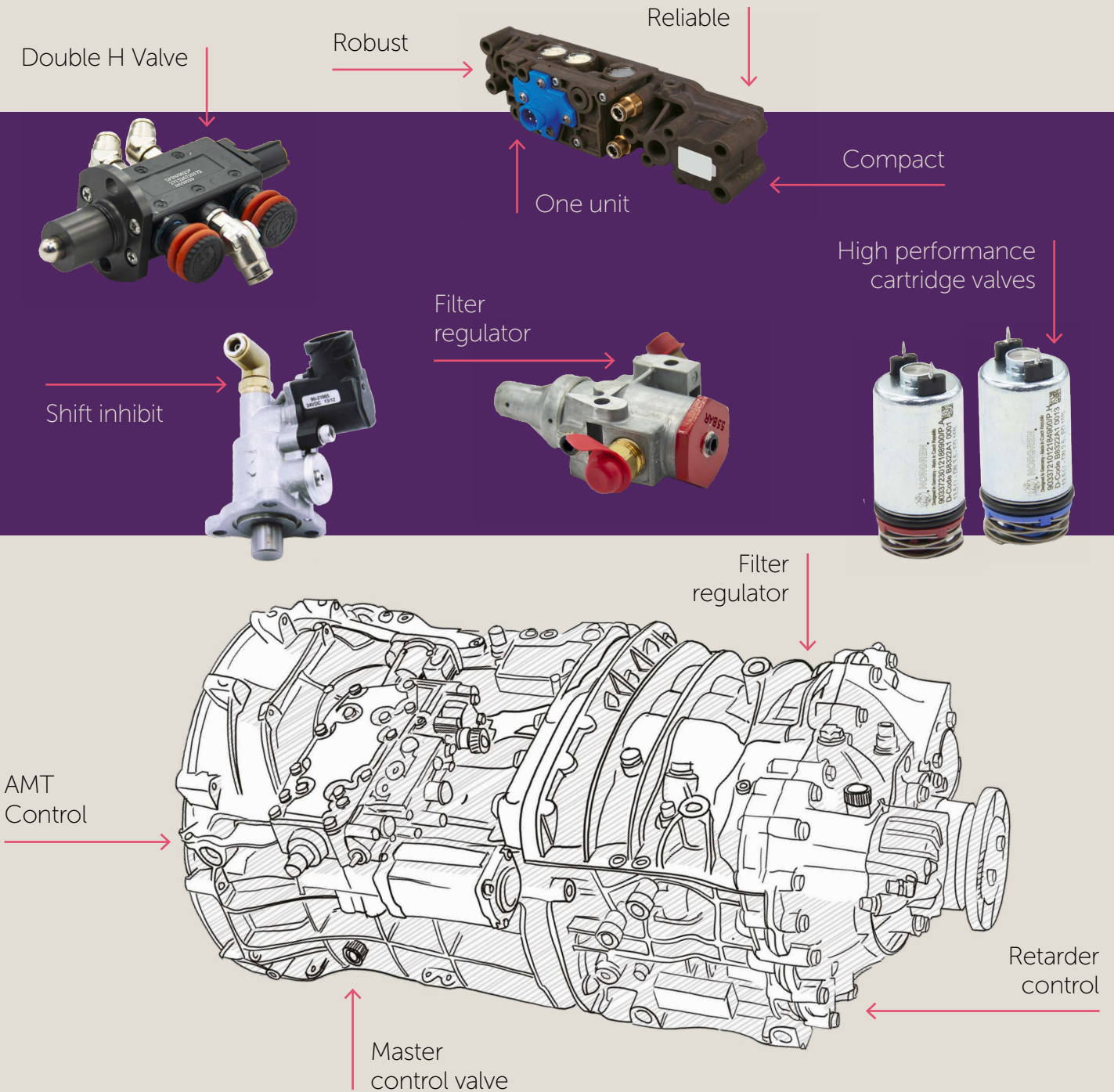

Chassis/Cab

Both standard and customised pneumatic control solutions that comply with all regulatory requirements for use in primary and auxiliary applications, reducing leakage, improving reliability and lowering total cost of ownership.

High performance, stackable solenoid valves have a single air supply when mounted in multi array, while manifolds reduce the overall weight and footprint.

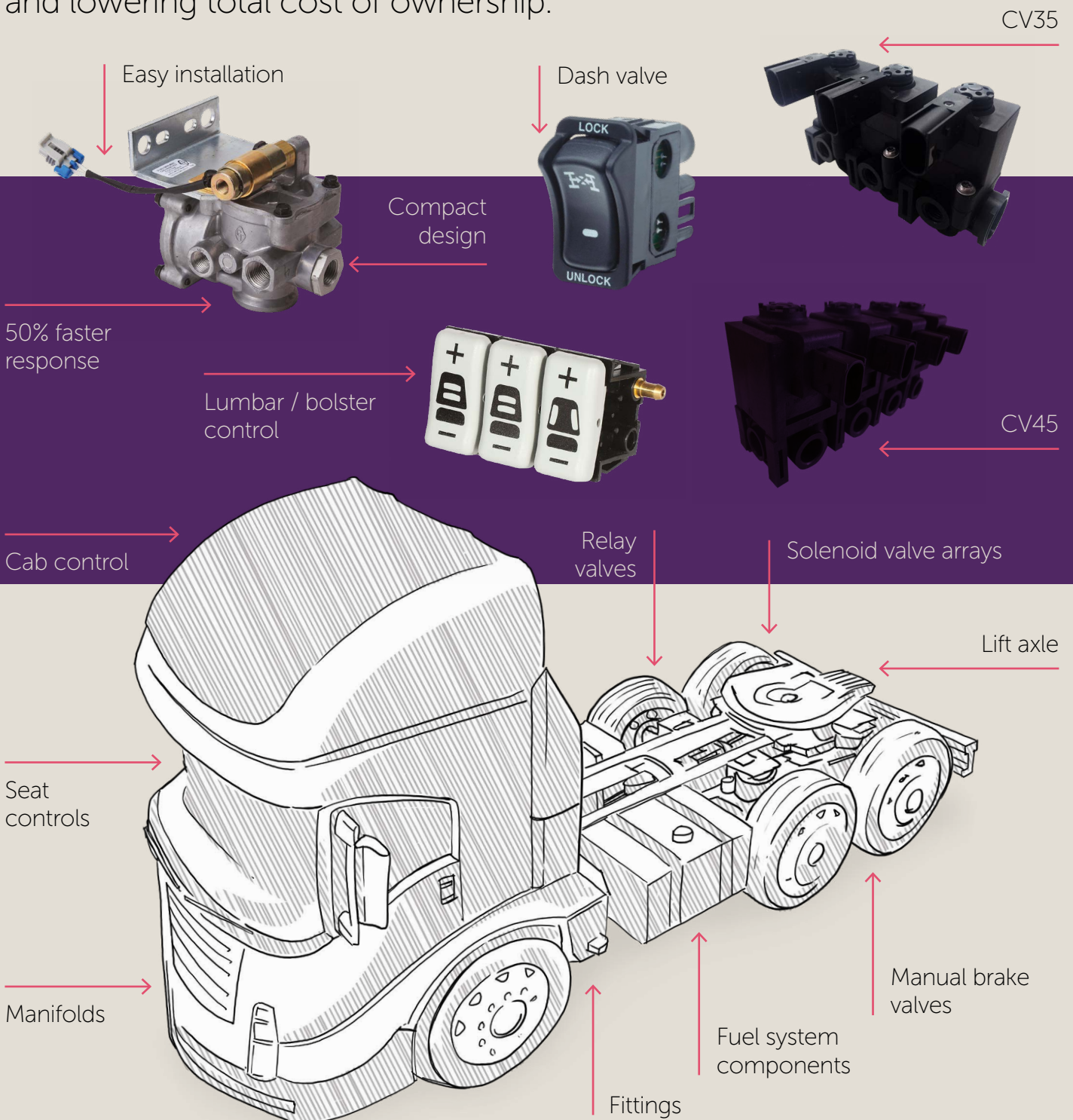

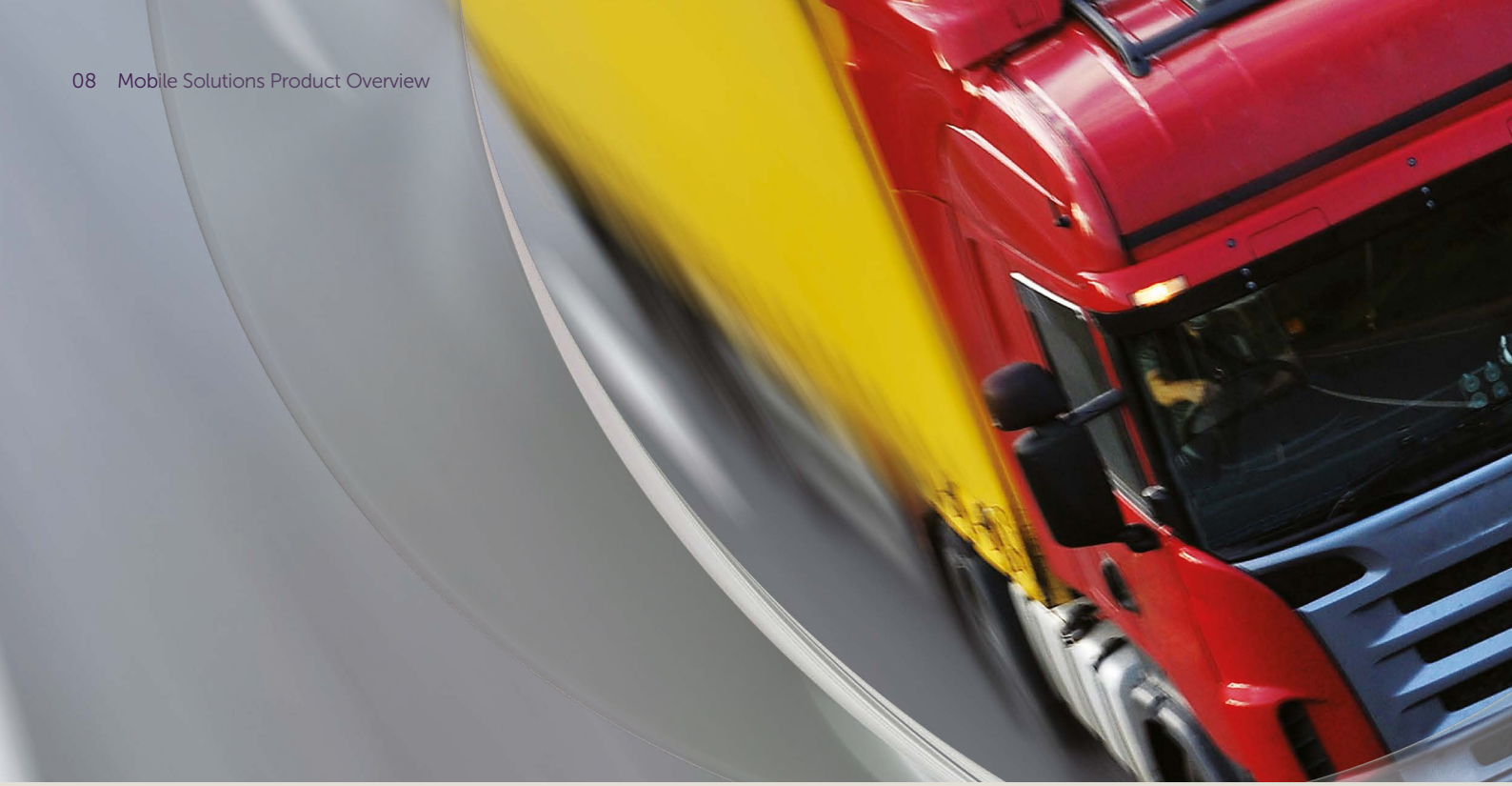

Powertrain Engine Solutions

Our proven valve and actuation technology has helped OEMs reach the highest regional emission standards.

We have developed a core set of products and technologies to assist with systems such as EGR, SCR, enhanced wastegate and diesel particulate filtration.

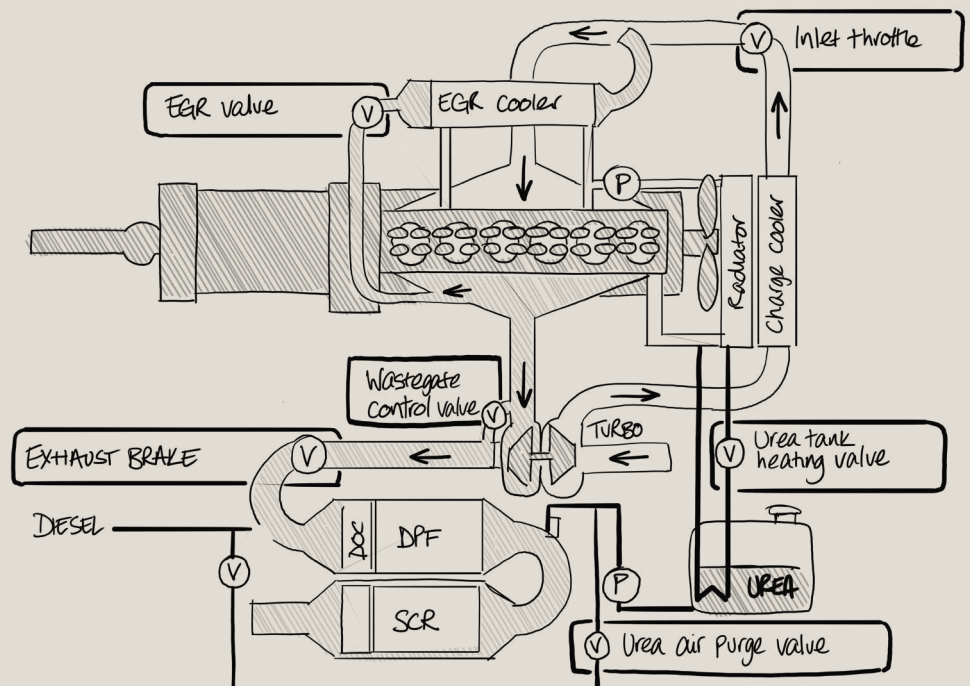

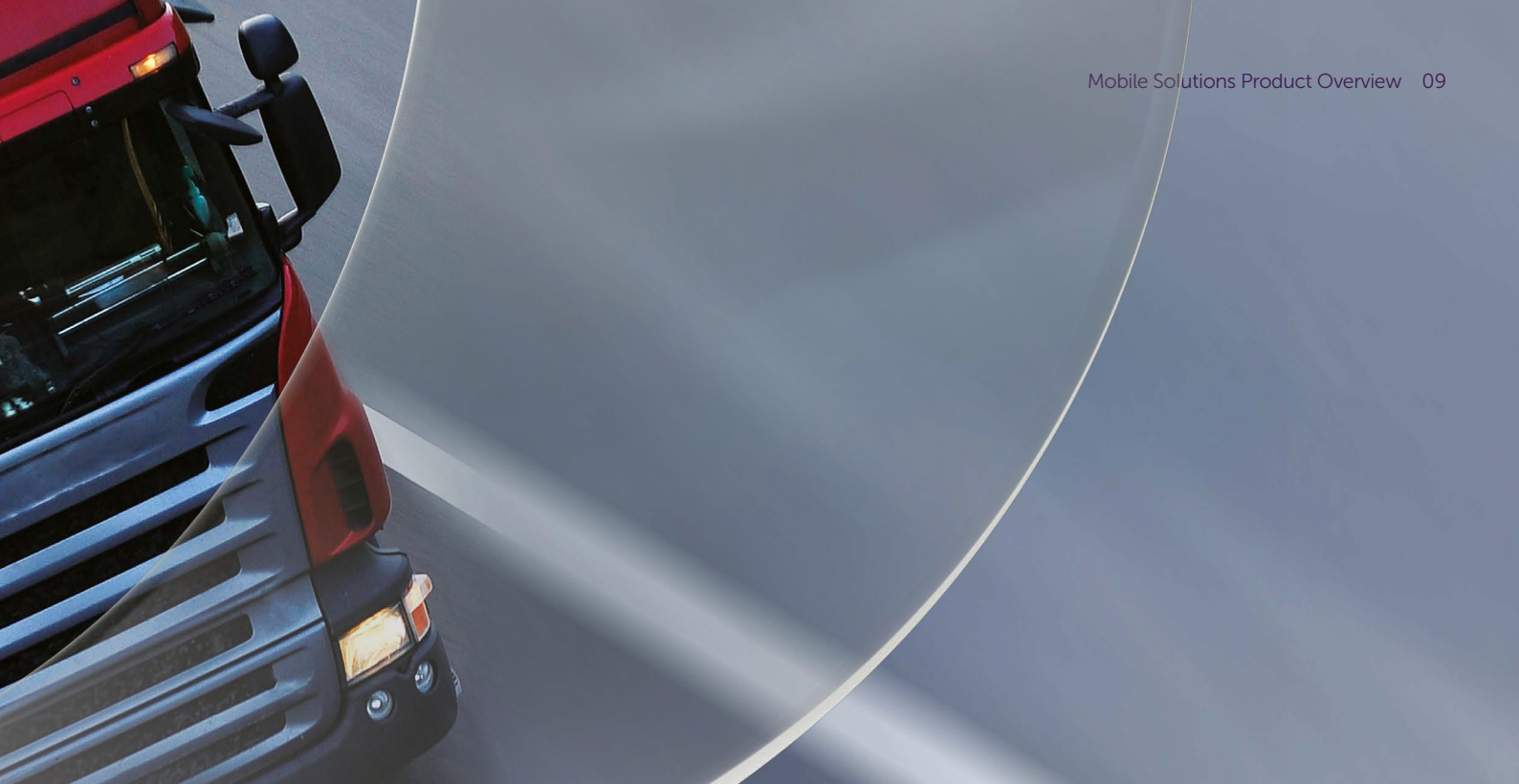

Norgren Inlet Throttles

This high-performance product provides egr assistance, maintains elevated exhaust temperature and enables rapid engine shutdown:

- High-durability brushless DC actuator
- Pipe-mounted, die-cast aluminium housing
- Stainless steel flap and shaft
- CAN J1939 smart actuator, 12V and 24V
- Safety spring return to normally open
- Compact direct drive

Norgren Smart proportional turbo wastegate control

We offer high-performance, advanced pneumatic control for the turbo wastegate (SWG) – a fully integrated closed loop control system that includes an ECU, pressure sensor and a proportional valve

- Communication with the engine and / or the vehicle ECU is possible
- Available with pressure or displacement feedback, and with PWM or CAN control
- Suitable for use with Euro IV, V, VI, EPA requirements, or Tier 4 final applications
- IP6K9K-rated enclosures

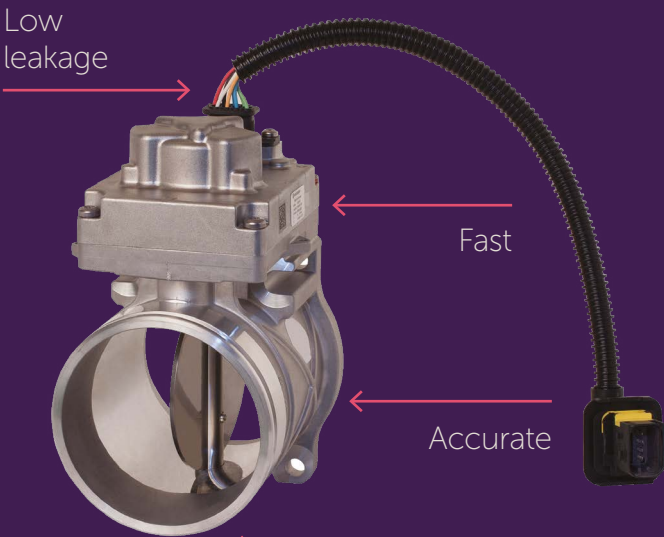



Solutions for Mobile Pneumatics

Our experience and expertise in the global Commercial Vehicle market has enabled us to work closely with a wide variety of customers who also need robust, reliable and proven solutions for pneumatic systems in their vehicles. We have been able to work with these customers to resolve challenging and critical applications across a range of industries, including:

To these customers we provide

- Tanker & Trailer manufacturers
- Body Builders
- Bus & Coach manufacturers
- Specialist Vehicle manufacturers (mining, agricultural)

Reliable, durable and proven products

Companies who operate across global markets need systems which will work reliably through extremes of temperature and environment. Our products are specially designed to perform in these conditions, with a particular focus on climate, temperature, thermal shock, corrosion, vibration, and mechanical shock. We manufacture special filters and regulators to ensure optimum air quality to our range of valves, actuators and fittings.

Precise proportional control

For applications which require precise variable control of pressure or flow in a system we have a complete range of industry-ready solutions which offer a range of low power and high accuracy options.

Smaller, lighter systems

With space and weight at a premium, we continue to develop products which maximise performance and resilience while minimising weight and space-claim. Our range of cartridge valves, valve arrays and fittings manifolds are specifically designed to meet these industry needs.

Industry certifications

We continue to develop products to meet and exceed industry regulations where they apply – our range of DOT FMVSS fittings for air brakes are used throughout the world. We also have secured DNVGL and BV marine certification for our proportional I/P – meaning it can be used across the world.



Improved performance & efficiency

- Our proportional fluid flow control products have delivered benefits to the agricultural industry by enabling more precise and responsive dispense systems.
- Working with trailer manufacturers to develop pneumatic systems to extend the length of trailers which provide haulage companies with greater fleet flexibility.
- Our proportional pressure control products have helped to extend the life of cleaning brushes and high pressure jets in a range of specialist municipal vehicles across the world.

Improved comfort and ergonomics

- We have developed a standard range of in-cab pneumatic seat-height, lumbar and suspension products to enhance operator comfort.
- We have developed an industry-leading motorized climate control system for coaches which delivers precise and quiet operation for passengers, while also delivering operational efficiencies to coach operators.

Reduced emissions

- Our marine-certified proportional pressure controllers have enabled shipbuilders and operators to reduce their emissions in line with new industry regulations.
- Our valve arrays that are adopted by leading OEM Vehicle manufacturers due to their resilience and performance in the most demanding conditions can also be used by specialist vehicle manufacturers to add functions to the vehicle providing seamless integration with the base vehicle.

Improved safety

- IMI provide bulk liquid trailer manufacturers with pneumatic systems to control safety handrails on top of tankers to ensure operator safety.
- Pneumatic valves with various operators (plunger, roller lever) provide safe a reliable interlocking for tanker vents to help prevent damage to tanks.
- Our range of in-cab pneumatic control switches and control cabinets enable operators to remain at a safe distance during tipper unloading.
- We work with bus and coach manufacturers to supply a range of passenger door systems which include manual overrides and automatic reverse functions to ensure passenger safety.
- We also manufacture electro-hydraulic control units to compensate for over-steering on municipal vehicles as well as pneumatic valves that can be used to pilot operate hydraulic systems particularly critical in environments that limit the use of electrical signals (underground mining, fuel tankers etc).

Tankers & Trailers

As haulage requirements have become more sophisticated we have developed our pneumatic capabilities to suit a wide range of systems and applications which are now found in today's modern tankers and trailers.

Typical applications that we support today include:

- DOT FMVSS/ DIN 74324 brake fittings
- Fifth wheel applications
- Control panels and cabinets
- Pneumatic interlocks for safety critical applications
- Extendable trailer applications
- Safety handrail control
- ATEX-rated process valves for tankers
- Air preparation equipment
- Lubrication manifold
- Pneumatic pilot system for hydraulics
- Load cover/ automatic sheeting control
- Tipper and tailgate control
- Variable tank volume and evacuation control
- Suction control

Fittings & Accessories



CV45

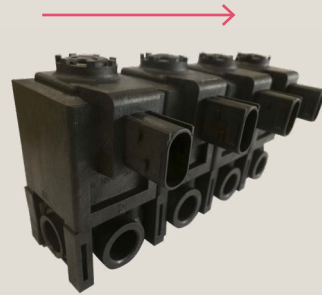

Actuators, valves and auxiliary fittings

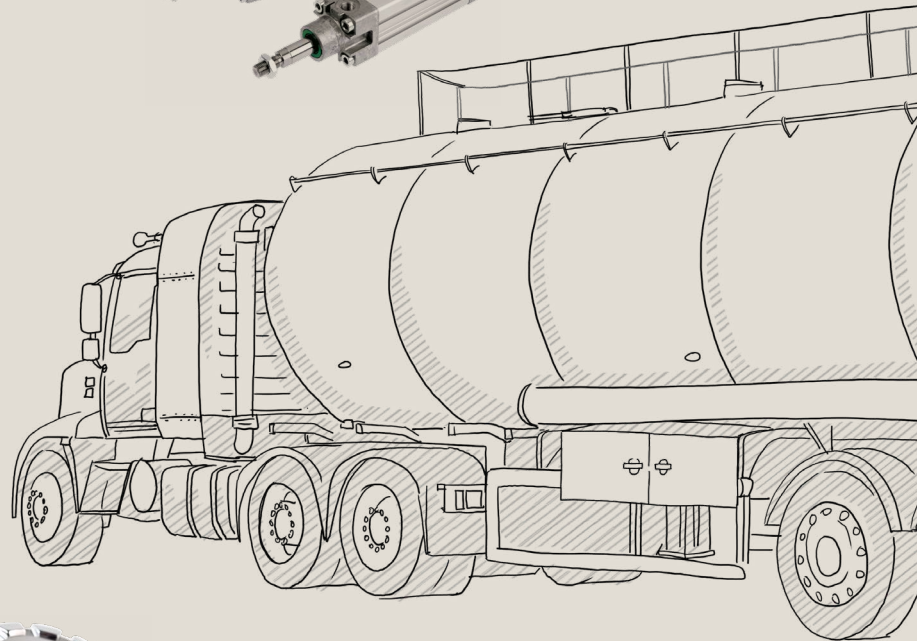
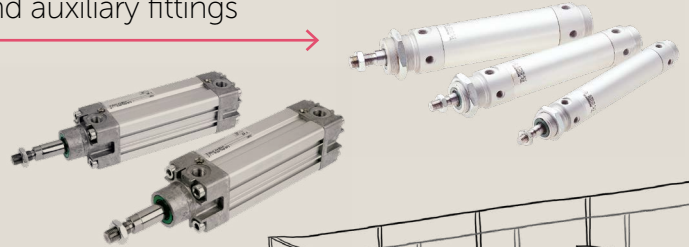

Metal body Super X valve



Fuel filler caps & vents

Control panels & cabinets



Air preparation equipment



Tank vent

Specialist bulk and tipper trailers often need pneumatic control of tailgates and specialist systems.



Push pull valve with status indicator

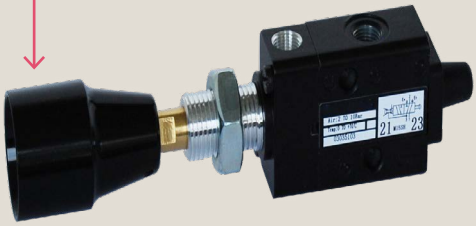

ATEX-rated process valves

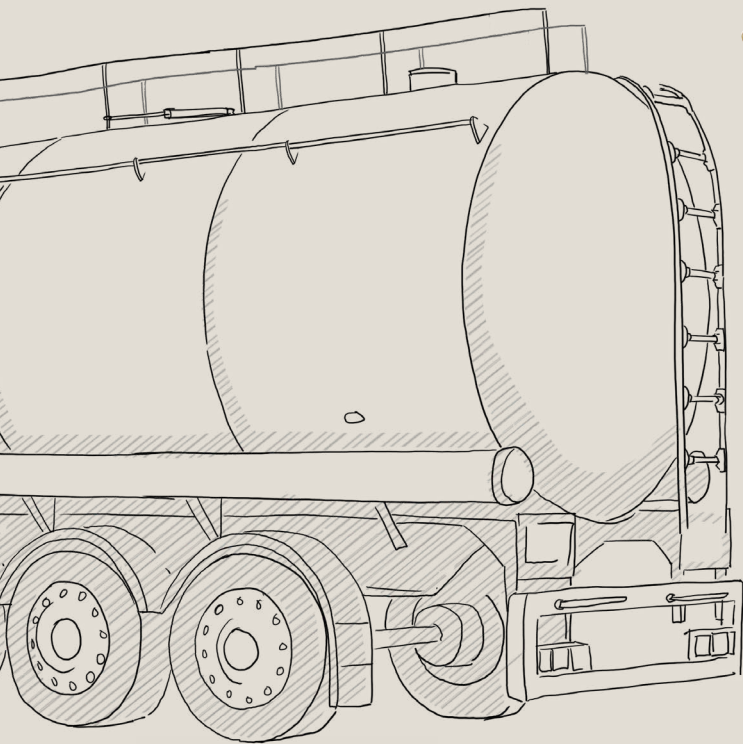

Our valves and actuators are used as pneumatic interlocks in a variety of applications - from car transporters to safety rails on bulk liquid tankers.



DOT FMVSS/ DIN
74324 air brake fittings



Push pull
valve

Norgren Body Builders

IMI provide solutions for a wide variety of applications for industry OEMs and specialist body builders. We have a long history of supplying reliable, high-performance products designed to meet the challenging environments and problem-solving needs of the industry.

Typical applications that we support today include:

- Tailgate and tipper control
- Side-wall locking
- Pneumatic hand rail actuation
- Pneumatic pilot system for hydraulics
- Load cover/ automatic sheeting control
- Pneumatic interlocks
- Boom control/ counter balance
- High pressure jetting control
- Wide sweep brush positioning
- Proportional brush pressure control
- Variable tank volume and evacuation control
- Suction control
- Spreading/ gritting control
- Pneumatic trailer coupling



Reliable actuators & valves

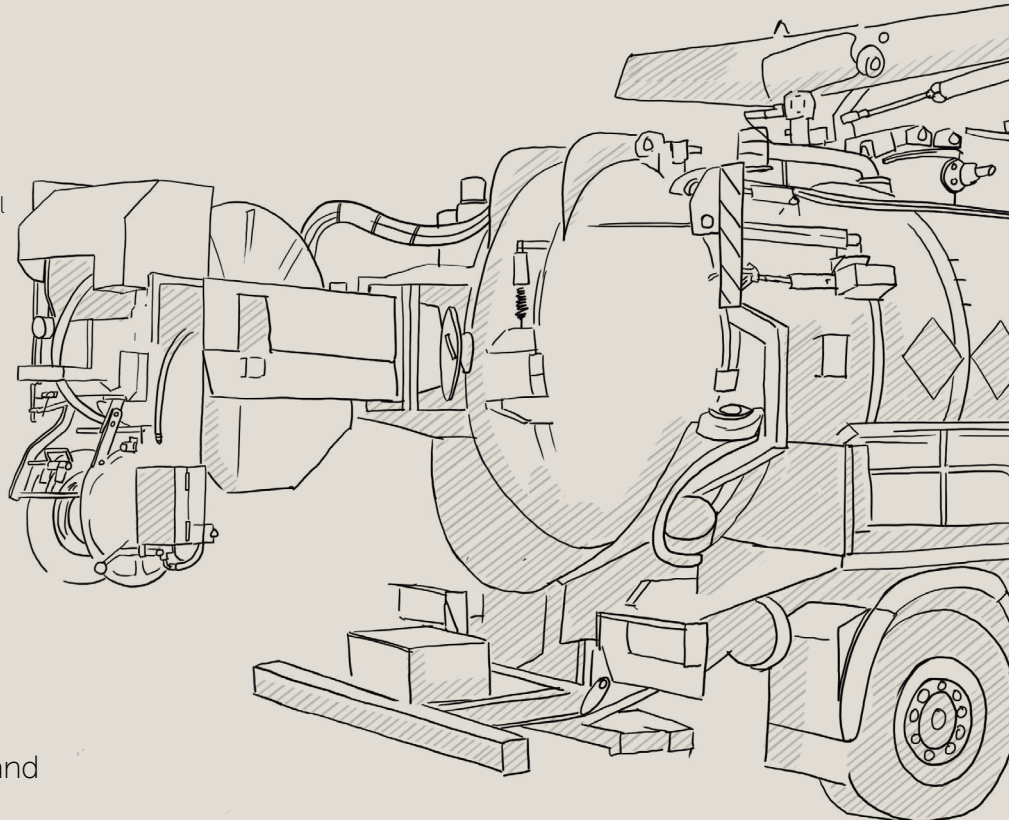

Actuators, valves and auxiliary fittings

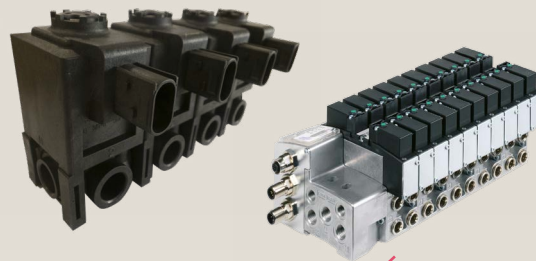

Valve arrays and manifolds



Angle seat valve

Motorized variable cooling control



Proportional control

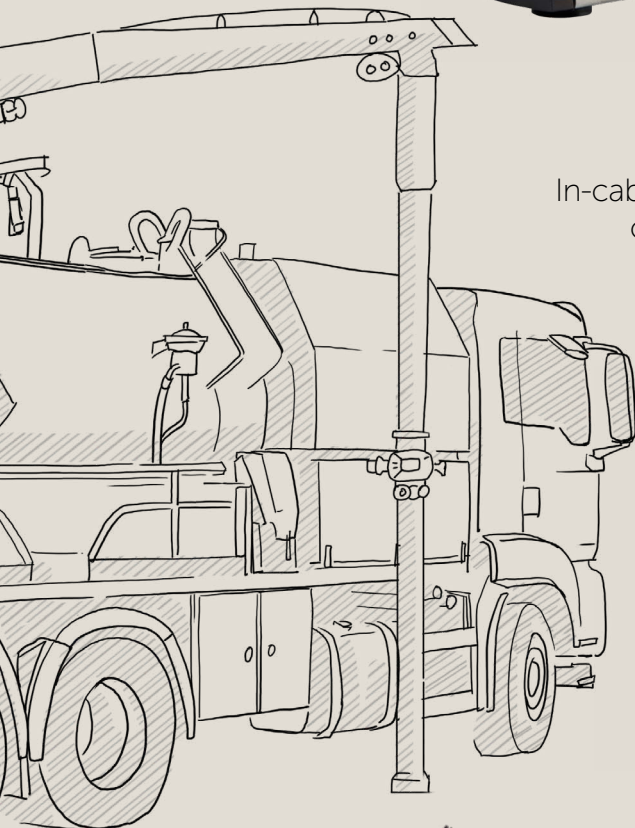

In-cab tipper control



Control panels & cabinets

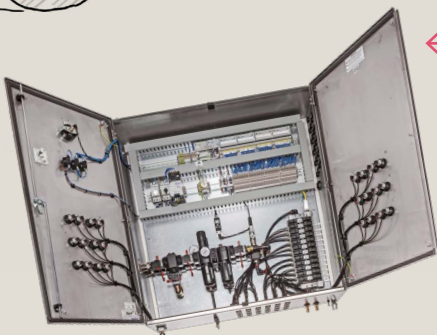

Our special air suspension valve manifolds enable chassis height adjustment according to load and conditions for a variety of specialist bodybuilder applications, including ambulances.



Other examples of specialist applications include pneumatic control of hydraulic systems as well as suction, boom counterbalance and tank filling/ emptying.



Municipal vehicles and fuel tankers both have requirements for pneumatic control panels and cabinets to ensure driver/ operator safety at all times.



Buses & Coaches

Passenger comfort and safety on today's modern buses and coaches remains a high priority. IMI supply a range of reliable and robust control valves for climate control and door-opening systems designed to operate in extreme temperatures.

Typical applications that we support today include:

- Climate control
- Door open/ close system with integrated anti entrapment
- Emergency door control/air release
- Disabled access systems
- Articulated bus safety and damping systems
- Battery cooling for hybrid buses
- DOT FMVSS DIN 74324 brake fittings
- Fuel filler caps (vented/ non-vented)
- Disabled access systems
- Kneeling control valves

PRA and IVAC cylinders for door actuation

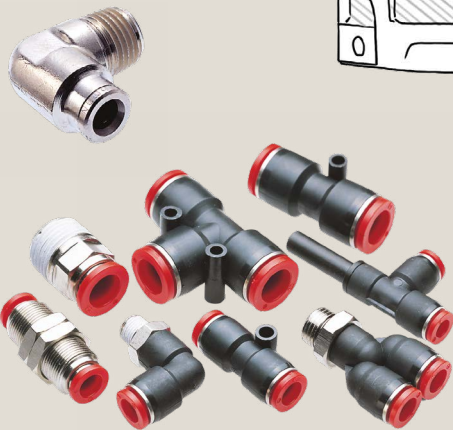
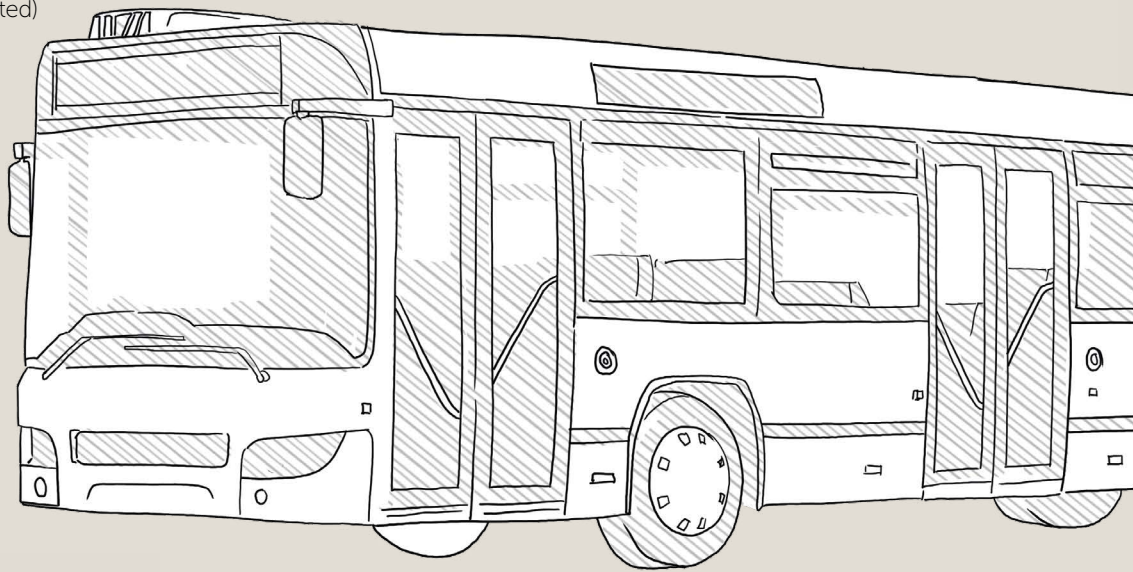

Fittings & Accessories



Control valves

Our high flow precision regulators control the response of the pantograph system according to height variations in electric overhead lines.



Climate control valves

Glycol filters



IMI have supplied door control systems for city buses and climate control systems for luxury coaches for many years.



Special actuators are used to maintain constant tensioning on main and auxiliary fan belts, delivering efficiency and ease of servicing.

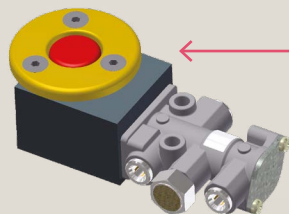
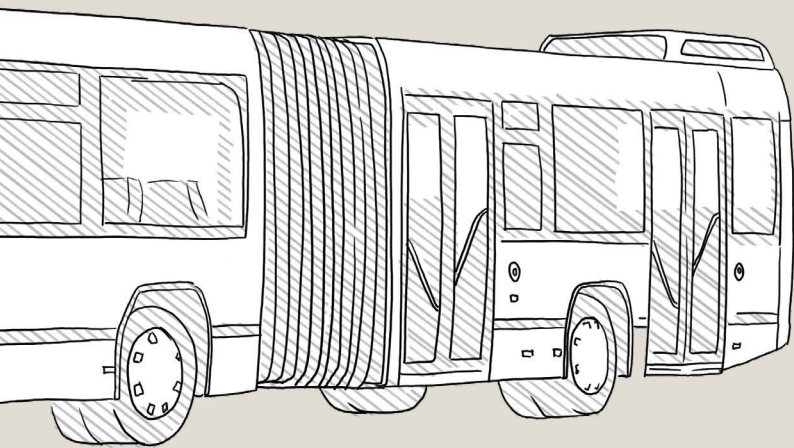

Emergency door valves

Door control systems

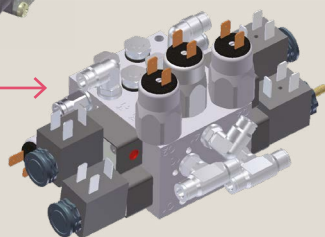

Norgren Actuators



A vast array of actuators – from ISO/VDMA profile to compact short stroke, rodless and roundline cylinders to rotary actuators, a range of shock absorbers and our more traditional actuator ranges.

A whole selection of simple and complex specifications are just a phone call or email away. Contact the team for fast, expert advice on the right product for your application. Each item is clearly listed to help ensure you get everything you need to get the job done.

Roundline Cylinders

RM/28000/M
ISO 6432
Ø 10 ... 25 mm



RT/57100/M
RT/57300/M
Ø 10 ... 40 mm



RT/57200/M
Ø 10 ... 63 mm



Compact Cylinders

RA/191000/M, .../MX
RA/193000/M, .../MX
ISO 21287
Ø 20 ... 63 mm



RA/192000/M
RA/192000/MX
ISO 21287
Ø 20 ... 125 mm



Profile Cylinders

PRA/802000/M,
RA/802000/M,
RA/8000, RA/8000/M
ISOLINE™ CYLINDER
Ø 32 ... 320 mm



RA/8000/M
ISO, VDMA, NFE
Ø 32 ... 320 mm



Servo motor

Servo motor
XXXXXX.9663.02400



Norgren Fuel Systems



A vast array of actuators – from ISO/VDMA profile to compact short stroke, rodless and roundline cylinders to rotary actuators, a range of shock absorbers and our more traditional actuator ranges.

A whole selection of simple and complex specifications are just a phone call or email away. Contact the team for fast, expert advice on the right product for your application. Each item is clearly listed to help ensure you get everything you need to get the job done.

Fuel tank caps



Return flow splitter
2252 Series



Fuel tank vent
201 Series & 2113-1



High-flow fuel tank vent
2989-11



Linegard® breakaway valves
2200-1



Norgren Air and Gas Preparation



Our air and gas preparation solutions protect sensitive and expensive instrumentation and controls from water, oil or particle contamination.

**Combination filter/
regulator & lubricator**
BL72, BL73, BL74
G1/4 ... G1/2



Pressure regulators
R07
G1/8, G1/4



Norgren Valves

IMI offers a number of safe, reliable and cost-effective integrated solenoid valve solutions for actuation control in upstream and downstream applications including the control of process pneumatic actuators and the control and handling of neutral and aggressive gases and liquids. Our valves are typically manufactured with stainless steel housings and Ex-proof coils, with a broad choice of materials for seals to suit the environmental and application specifications.

In-Line Valves And Valve Islands

V60 ... 63
3/2, 2x3/2, 5/2 & 5/3, G1/8 ... G1/2



VCB22
3/2, 5/2 & 5/3 M5, G1/8...G1/2



VS18 - Mini ISO
2 x 2/2, 2 x 3/2, 5/2 or 5/3, size 18 mm

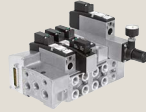

Solenoid Poppet Valves

90-22327, 90-22295
3/2



Excel 32, V04 & V05
2/2 and 3/2, NO/NC G1/8, G1/4



Excel 32, V04 & V05
2/2 and 3/2, NO/NC G1/8, G1/4



ASAP Series Air Solenoid Accessory Pack



Manual and Mechanical Valves

Super X
3/2, 5/2 and 5/3, G1/8, G1/4 and 6 mm PIF



VHLA Series, 4/2 and 4/3
3/2



Natural Gas Valves

1406076.4280.02400, 1406076.9356.02400
3/2



85410/85430
2/2





Seat and Dash Valves

3281 Series - Dash valve
3/2



3013 -4 Series - Paddle Seat Control Valve



3013-5 Series - Electric/Pneumatic combination paddle seat valve



134-4 Series - Removable Knob Seat Valve



3000 Series - Electric/Pneumatic combination valve



Toggle Switches

3200 -1A Series - Air/Electric Switch



3202-1A Series - Air Switch



Flipper Control Valves

3220-1 Series



3222-1 Series



Other valves and accessories

5040 Series Lift Axle Control Module
3/2



4111 Series Rapid Dump Valve



223 Series Pressure Protection Valves (PPV)



Check Valves



4000 Series Fastbrake Quick Exhaust Valve



CV85 Series Urea Tank Heating Valve
2/2



Diesel Air Inlet Throttle (DAIT)



Smart Wastegate



Bus Coolant Valve



CV35
3/2, M12 x 15



Norgren Switches, Fittings, Tubings & Accessories

Pressure sensor technology is critical when pressure monitoring for higher plant security or pressure control for higher functionality are needed in an application.

Electro-Mechanical Pressure Switch

18D Pneumatic
-1 ... 30 bar



18D Hydraulic
5 ... 420 bar



04015600 Pneumatic
0 ... 10 bar



Pneufit

10 Series
Push-in fittings



C Series



DOT, TUV Commercial Vehicle Push to Connect Fittings

Fleetfit Series
Inch Tube Range



97400 Fleetfit
Metric Tube Range



Exhaust Guard

0613422, 0613423



Tubing & Hoses

Ø 3 ... 16 mm O/D



Low Pressure Rotowinks

Pneumatic Visual Indicators





Series PA2

Pneumatic Visual Indicators



High Pressure Rotowinks

Pneumatic Visual Indicators
G1/8



Inline Pressure Protection Valves (Ppv)

5200-75



Air Preparation Accessories

Gauges, Auto-drain,
Drip leg drain



Shuttle valve

T65
G1/8 & G1/4



Commercial Vehicles

Mobile Solutions Product Overview

Due to our policy of continuous development, IMI reserves the right to change specifications without prior notice.

zXXXXBR en/01/21

